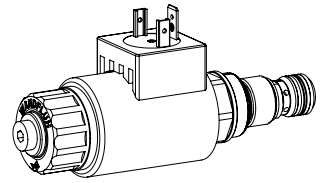

Solenoid operated poppet valve cartridge

- ◆ direct operated
- ◆ 2/2- and 3/2-way
- ◆ $Q_{max} = 30 \text{ l/min}$
- ◆ $p_{max} = 350 \text{ bar}$

M18 x 1,5
ISO 7789 / Wandfluh standard

DESCRIPTION

Direct operated 2/2- and 3/2-way solenoid poppet valve in screw-in cartridge construction for cavity according to ISO 7789 / Wandfluh standard. By means of the pressure tight switching solenoid, the pressure compensated, metallically sealing poppet spool is either opened or closed. The seat spool guide is sealed by means of an O-ring.

APPLICATION

Wandfluh solenoid operated poppet valve cartridges are used where tight closing functions are essential like leakage-free load holding, clamping or gripping. For machining the cartridge cavity in steel and aluminum blocks, cavity tools are available (hire or purchase). Please refer to the data sheets in register 2.13.

SYMBOL

„Normally open“ AB

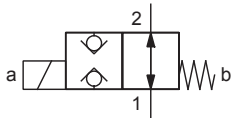

„Normally closed“ BA

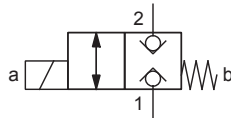

FG

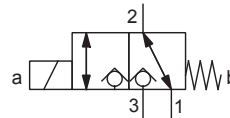
TYPE CODE

		S D S PM18 - <input type="text"/> - <input type="text"/> / <input type="text"/> <input type="text"/> - <input type="text"/> <input type="text"/> # <input type="text"/>	
Poppet valve			
Direct operated			
Solenoid			
Screw-in cartridge M18 x 1,5			
Designation of symbols acc. to table			
Nominal voltage U_N	12 VDC <input type="text"/> G12	115 VAC <input type="text"/> R115	
	24 VDC <input type="text"/> G24	230 VAC <input type="text"/> R230	
	without coil <input type="text"/> X5		
Slip-on coil	Metal housing round with one-sided collar <input type="text"/> V	(only G12 and G24)	
	Metal housing square with one-sided collar <input type="text"/> N		
Connection execution	Connector socket EN 175301-803 / ISO 4400 <input type="text"/> D		
	Connector socket AMP Junior-Timer <input type="text"/> J	(only for $U_N \leq 75 \text{ VDC}$)	
	Connector Deutsch DT04 - 2P <input type="text"/> G	(only for $U_N \leq 75 \text{ VDC}$)	
Sealing material	NBR <input type="text"/>		
	FKM (Viton) <input type="text"/> D1		
	NBR 872 <input type="text"/> Z604		
Armature tube	with screw plug HB0 <input type="text"/>		
	with manual override <input type="text"/> HB4,5		
Design index (subject to change)			

1.11-2051

GENERAL SPECIFICATIONS

Designation	2/2-, 3/2-way poppet valve
Construction	Direct operated
Mounting	Screw-in cartridge construction
Nominal size	M18 x 1,5 according to ISO 7789 / Wandfluh standard
Actuation	Switching solenoid
Ambient temperature	-25...+70 °C
Weight	0,46 - 0,48 kg
MTTFd	150 years

HYDRAULIC SPECIFICATIONS

Working pressure	$p_{max} = 350$ bar
Maximum volume flow	$Q_{max} = 30$ l/min, see characteristics
Leakage oil	Poppet type, max. 0,15 ml / min (approx. 3 drops / min) at 30 cSt
Fluid	Mineral oil, other fluid on request
Viscosity range	12 mm ² /s...320 mm ² /s
Temperature range fluid	-25...+70 °C (NBR) -20...+70 °C (FKM) -40...+70 °C (NBR 872)
Contamination efficiency	Class 20 / 18 / 14
Filtration	Required filtration grade $\beta_{10...16} \geq 75$, see data sheet 1.0-50

ELECTRICAL SPECIFICATIONS

Protection class	Connection execution D: IP65 Connection execution J: IP66 Connection execution G: IP67 and IP69K
Relative duty factor	100 % DF
Switching frequency	5'000 / h
Service life time	10 ⁷ (number of switching cycles, theoretically)
Voltage tolerance	± 10 % with regard to nominal voltage
Standard nominal voltage	12 VDC, 24VDC, 115 VAC, 230 VAC AC = 50 to 60 Hz, rectifier integrated in the connector socket

Note! Other electrical specifications see data sheet 1.1-168 (slip-on coil V) and 1.1-175 (slip-on coil N)



ACTUATION

Actuation	Switching solenoid, wet pin push type, pressure tight
Execution	V.E37 / 19 x 50 (Data sheet 1.1-168) N.S35 / 19 x 50 (Data sheet 1.1-175)
Connection	Connector socket EN 175301 – 803 Connector socket AMP Junior-Timer Connector Deutsch DT04 – 2P

SURFACE TREATMENT

- ◆ The cartridge body, the slip-on coil and the armature tube are zinc-nickel coated

SEALING MATERIAL

NBR or FKM (Viton) as standard, choice in the type code

PERFORMANCE SPECIFICATIONS

Oil viscosity $\nu = 30$ mm²/s

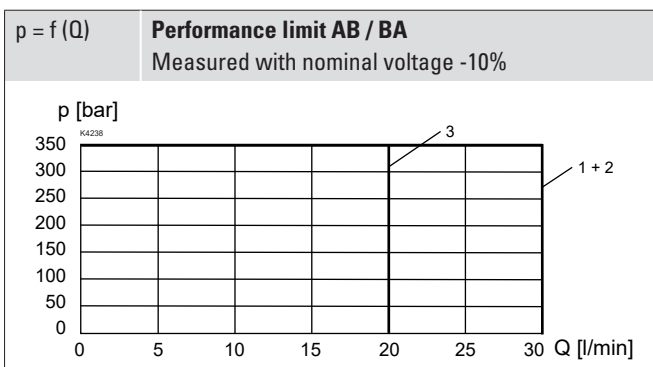

Execution	Flow direction	
	1 → 2	2 → 1
SDSPM18-AB	3	1
SDSPM18-BA	2	1

PERFORMANCE SPECIFICATIONS

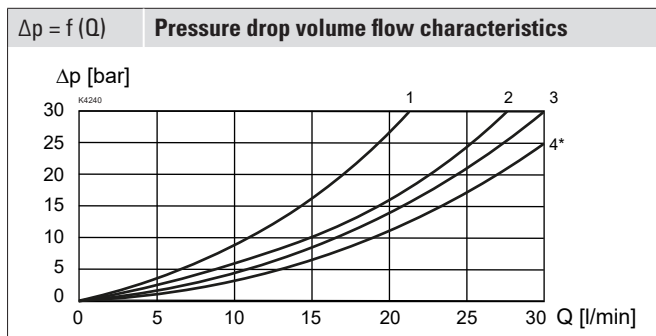
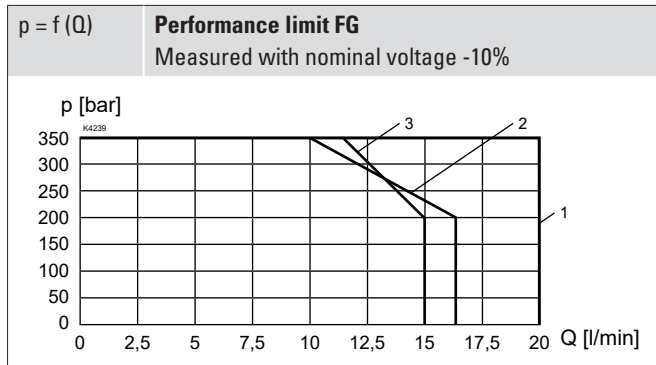
 Oil viscosity $\nu = 30 \text{ mm}^2/\text{s}$

SDSPM18	Typ	Flow direction	Switching times	
			Switching on	Switching off
	AB	1 → 2	approx. 40 ms	approx. 20 ms
		2 → 1	approx. 40 ms	approx. 10 ms
	BA	1 → 2	approx. 40 ms	approx. 30 ms
		2 → 1	approx. 30 ms	approx. 30 ms
	FG	1 → 2	approx. 40 ms	approx. 10 ms
		2 → 1	approx. 40 ms	approx. 10 ms
		2 → 3	approx. 40 ms	approx. 40 ms
		3 → 2	approx. 40 ms	approx. 20 ms

Execution	Flow direction			
	1 → 2	2 → 1	2 → 3	3 → 2
SDSPM18-FG	3	1	1	2

Execution	Flow direction			
	1 → 2	2 → 1	2 → 3	3 → 2
SDSPM18-AB	4	4	-	-
SDSPM18-BA	3	3	-	-
SDSPM18-FG	2	2	1	1

 * Δp 80 bar at 40 l/min

Note!

The switching times depend on the volume flow, pressure and viscosity. In case of very large volume flows, the switching time for closing can get considerably longer.

HYDRAULIC CONNECTION

Cavity drawing according to ISO 7789-18-01-0-98

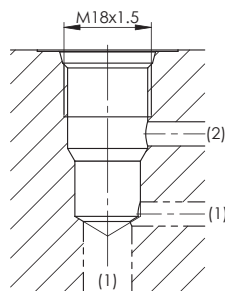
Note!

For detailed cavity drawing and cavity tools see data sheet 2.13-1002

HYDRAULIC CONNECTION

Cavity drawing according to Wandfluh standard

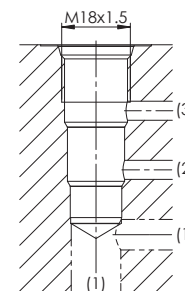
Note!

For detailed cavity drawing and cavity tools see data sheet 2.13-1020

DIMENSIONS

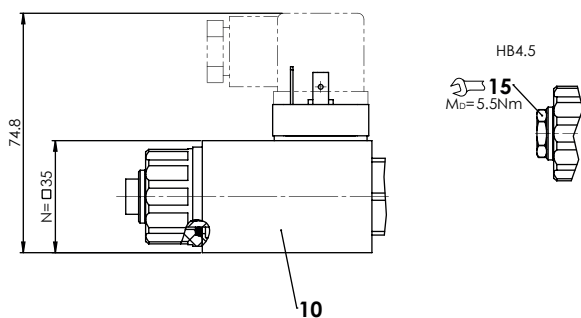
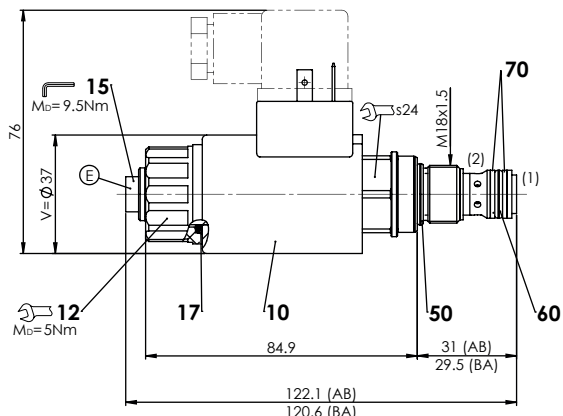
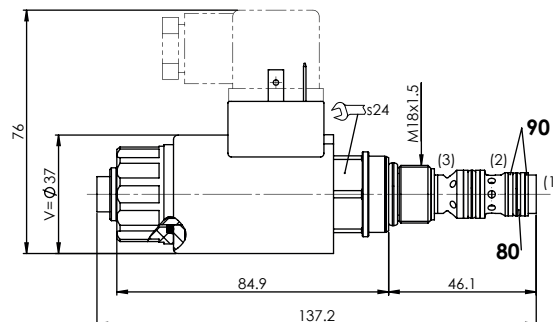
SDSPM18-AB / BA

SDSPM18-FG

PARTS LIST

Position	Article	Description
10	206.2...	V.E37 / 19 x 50
	260.5...	N.S35 / 19 x 50
12	154.2700	Knurled nut
15	253.8000	HB4,5 manual override
	239.2033	HB0 Screw plug
	251.0907	Seal kit SDSPM18

Seal kit consisting of:

17	O-ring	ID 18,72 x 2,62
50	O-ring	ID 15,60 x 1,78
60	O-ring	ID 11,11 x 1,78
70	Back. ring	PTFE rd 12,1 x 15 x 1,4
80	O-ring	ID 9,25 x 1,78
90	Back. ring	PTFE rd 10,6 x 13,5 x 1,4

STANDARDS

Cartridge cavity	ISO 7789 / Wandfluh standard
Solenoids	DIN VDE 0580
Connection execution D	EN 175301 – 803
Protection class	EN 60 529
Contamination efficiency	ISO 4406

ACCESSORIES

Threaded body	Data sheet 2.9-2xx
Technical explanations	Data sheet 1.0-100
Filtration	Data sheet 1.0-50
Relative duty factor	Data sheet 1.1-430

MANUAL OVERRIDE

Screw plug (HB0), no actuation possible

Optionally: HB4,5, HN(K) or HG(K)

→ See data sheet 1.1-311

INSTALLATION NOTES

Mounting type	Screw-in cartridge M18 x 1,5
Mounting position	Any, preferably horizontal
Tightening torque	$M_D = 40 \text{ Nm}$ Screw-in cartridge $M_D = 5 \text{ Nm}$ knurled nut $M_D = 9,5 \text{ Nm}$ HB0 $M_D = 5,5 \text{ Nm}$ HB4,5

Wandfluh AG Postfach CH-3714 Frutigen
 Tel. +41 33 672 72 72 Fax +41 33 672 72 12 sales@wandfluh.com