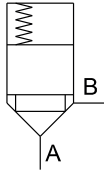
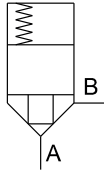
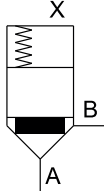
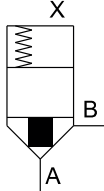

2/2-way slip-in cartridge valves

- $Q_{max} = 2260$ l/min
- $p_{max} = 630$ bar

NG 40
 DIN ISO 7368

2/2-WAY FUNCTION

Area ratio A:X	1:1,06 X	1:1,5 X
		
Type Execution	CSEN40-11 Standard	CSEN40-15 Standard
		
Type Execution	CDEN40-11 with damping	CDEN40-15 with damping

PRESSURE RELIEF

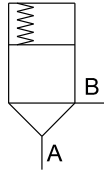
Area ratio A:X	1:1,0 X
	
Type Execution	CPEN40-10 Standard

TYPE CODE

2/2-way slip-in cartridge valve		C		<input type="checkbox"/>	EN40	-	<input type="checkbox"/>	/	<input type="checkbox"/>	/	<input type="checkbox"/>	-	<input type="checkbox"/>	#	<input type="checkbox"/>
Seat construction		<input type="checkbox"/>	S												
Seat construction with damping		<input type="checkbox"/>	D												
Pressure function		<input type="checkbox"/>	P												
Nominal size 40, Enhanced															
Area ratio	1:1	<input type="checkbox"/>	10	For pressure function only											
	1:1,06	<input type="checkbox"/>	11												
	1:1,5	<input type="checkbox"/>	15												
Opening pressure A to B	0 bar (without spring)	<input type="checkbox"/>	0												
Nominal	0.5 bar	<input type="checkbox"/>	05												
	1.0 bar	<input type="checkbox"/>	10												
	2.0 bar	<input type="checkbox"/>	20												
	4.0 bar	<input type="checkbox"/>	40												
Orifice in poppet spool	closed	<input type="checkbox"/>													
Sealing material	NBR	<input type="checkbox"/>													
	FKM	<input type="checkbox"/>	D1	(Viton)											
Design-Index (subject to change)															

GENERAL SPECIFICATIONS

Construction	2/2-way slip-in cartridge valves
Mounting position	any
Mounting dimensions	according to DIN ISO 7368
Ambient temperature	-30...+80 °C
Weight spool	m = 0,500 kg (1:1,5)
Weight total	m = 1,742 kg (1:1,5; without spring)
MTTFd	150 years

HYDRAULIC SPECIFICATIONS

Fluid	Mineral oil, other fluid on request
Contamination efficiency	ISO 4406:1999, class 18/16/13 (Required filtration grade $\beta_{6...10} \geq 75$) refer to data sheet no. 1.0-50/2
Viscosity range	12 mm ² /s...320 mm ² /s
Fluid temperature	-20...+80 °C (FKM) -30...+80 °C (NBR)
Operating pressure	$p_{max} = 630$ bar (connections A, B, X) CLEN $p_{max} = 420$ bar CPEN connection X, X-A = < 420 bar max. cover pressure to be observed
Max. volume flow	$Q_{max} = 2260$ l/min at v = 30 m/s
Pilot oil volume	$Q_{st} = 25,7$ cm ³ $Q_{st} = 21,1$ cm ³ (Pressure function)

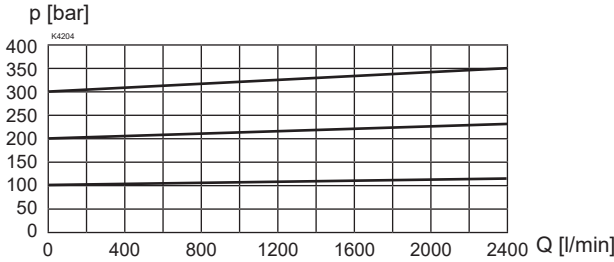
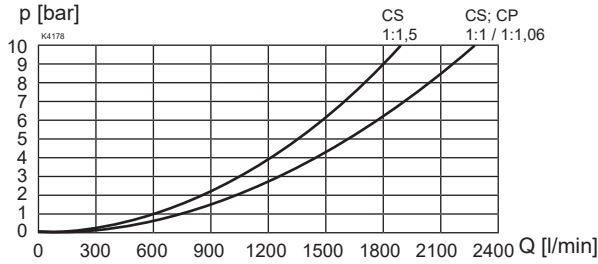
CHARACTERISTICS Oil viscosity $\nu = 30 \text{ mm}^2/\text{s}$
 $\Delta p = f(Q)$ Pressure drop / volume flow characteristics

CHARACTERISTICS

Nominal	Opening pressure [bar]			
	0,5	1,0	2,0	4,0

Area ratio	Flow direction A to B			
	1:1	0,4	0,8	1,6
1:1,06	0,4	0,9	1,7	3,4
1:1,5	0,6	1,2	2,5	4,9

Area ratio	Flow direction B to A			
	1:1	-	-	-
1:1,06	6,6	13,2	26,4	52,9
1:1,5	1,1	2,2	4,4	8,7

Pressure spring	Article no.			
		053.6412	053.7416	053.7415

DIMENSIONS

CSEN40-15

CPEN40-10

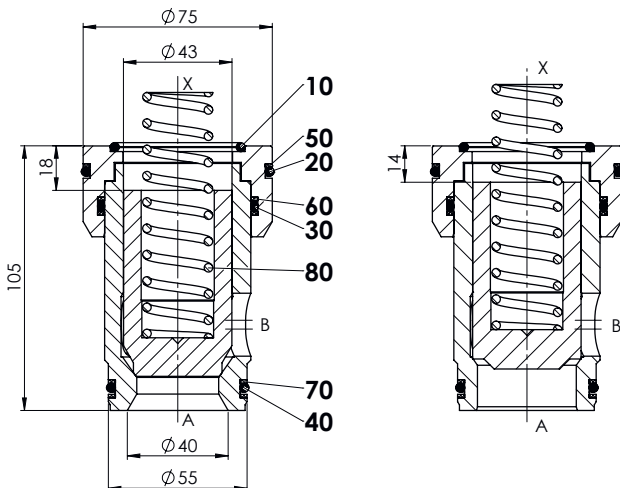
PARTS LIST

Position	Description	Seal kit
10	O-ring ID 47,22 x 3,53	•
20	O-ring ID 66,27 x 3,53	•
30	O-ring ID 56,74 x 3,53	•
40	O-ring ID 47,22 x 3,53	•
50	Backup ring rd 66,0 x 71,6 x 1,4	
60	Backup ring rd 58,0 x 63,6 x 1,4	
70	Backup ring rd 46,5 x 52,1 x 1,4	
80	Pressure spring 27,8	

SEAL KIT

251.8610	Seal kit C.E.40	NBR
251.8611	Seal kit C.E.40	VITON

HYDRAULIC CONNECTION

Cavity drawing according to ISO 7368

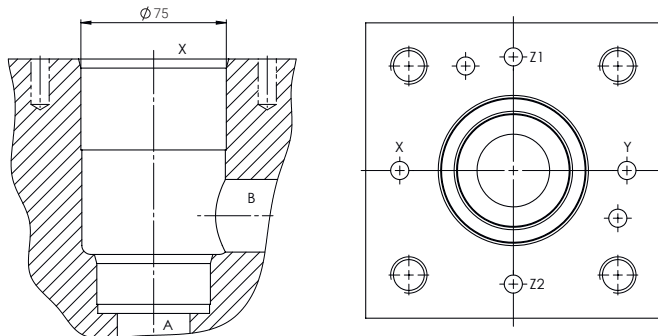
INSTALLATION NOTES

Mounting type	Slip-in cartridge
Mounting position	Any, preferably horizontal
Dismounting	Dismounting tool DW-C.E.40
	Article no. 983.3012

Important! For detailed cavity drawing and cavity tools see data sheet 2.13-1024

Note! The length of the cover fixing screws to be used depends on the base material of the valve body and on the maximum system pressure.