

Pressure relief cartridge

Leakage-free

- ◆ direct operated
- ◆ $p_{max} = 450 \text{ bar}$
- ◆ $p_{Nmax} = 420 \text{ bar}$
- ◆ $Q_{max} = 100 \text{ l/min}$

M22 x 1,5
ISO 7789

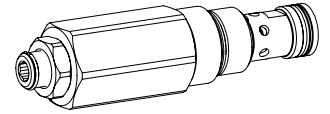

DESCRIPTION

Direct operated poppet type pressure relief valve in screw-in cartridge construction for cavity according to ISO 7789. The valve is closed in the neutral position. If the pressure in P (1) exceeds the adjusted value of the valve, the excessive pressure is drained to T (2). The back pressure at T (2) is added to the adjusted value. T (2) can be charged up to the maximum. Hardened precision parts ensure virtually leakage-free closing. Rapid switching with low hysteresis and excellent stability over the whole flow range.

APPLICATION

These valves are used for limiting the operating pressure in the hydraulic system. Can be used in double pressure relief switches. For machining the cartridge cavity in steel and aluminum blocks, cavity tools are available (hire or purchase). Please refer to the data sheets in register 2.13.

SYMBOL

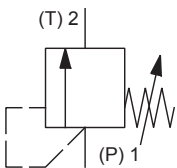

ACTUATION

Actuation	Adjustment spindle M12 x 1
Execution	S = blockable key adjustment
Actuation angle	$\alpha_b = 1800^\circ$ (5 rotations)
Actuation stroke	$S_b = 5 \text{ mm}$

TYPE CODE

		B E S PM22 - <input type="text"/> - <input type="text"/> # <input type="text"/>	
Pressure relief valve			
Direct operated, leakage-free			
Type of adjustment	Key		
Screw-in cartridge M22 x 1,5			
Nominal pressure range p_N	63 bar <input type="text" value="63"/>	210 bar <input type="text" value="210"/>	420 bar <input type="text" value="420"/>
Sealing material	NBR <input type="text"/>	FKM (Viton) <input type="text" value="D1"/>	NBR 872 <input type="text" value="Z604"/>
Design index (subject to change)			

2.1-539

GENERAL SPECIFICATIONS

Designation	Pressure relief valve
Construction	Direct operated
Mounting	Screw-in cartridge construction
Nominal size	M22 x 1,5 according to ISO 7789
Actuation	Manually
Ambient temperature	-25...+90 °C
Weight	0,30 kg $p_N = 210$ bar, 420 bar 0,24 kg $p_N = 63$ bar
MTTFd	150 years

HYDRAULIC SPECIFICATIONS

Working pressure	$p_{max} = 450$ bar
Tank pressure	$p_{Tmax} = 210$ bar
Nominal pressure range	$p_N = 63; 210; 420$ bar
Minimum pressure	See characteristics
Volume flow range	$Q = 0,1 \dots 100$ l/min
Leakage oil	Poppet type, max. 0,15 ml / min (approx. 3 drops / min) at 30 cSt
Fluid	Mineral oil, other fluid on request
Viscosity range	12 mm ² /s...320 mm ² /s
Temperature range fluid	-25...+90 °C (NBR) -20...+90 °C (FKM)
Contamination efficiency	Class 18 / 16 / 13
Filtration	Required filtration grade $\beta_{6 \dots 10} \geq 75$, see data sheet 1.0-50

PERFORMANCE SPECIFICATIONS

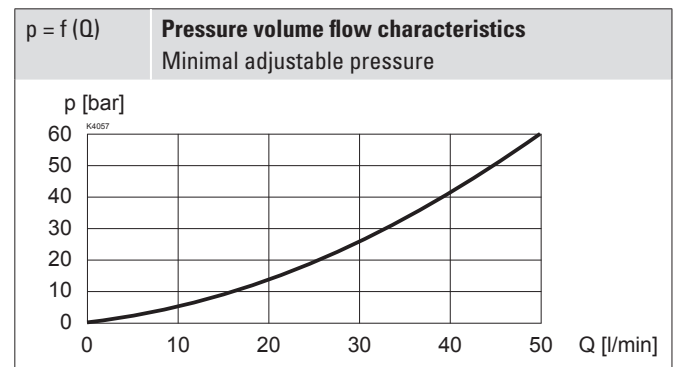
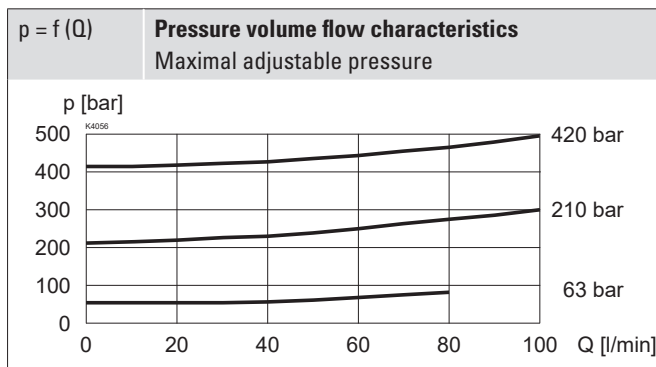
 Oil viscosity $\nu = 30$ mm²/s

DIMENSIONS

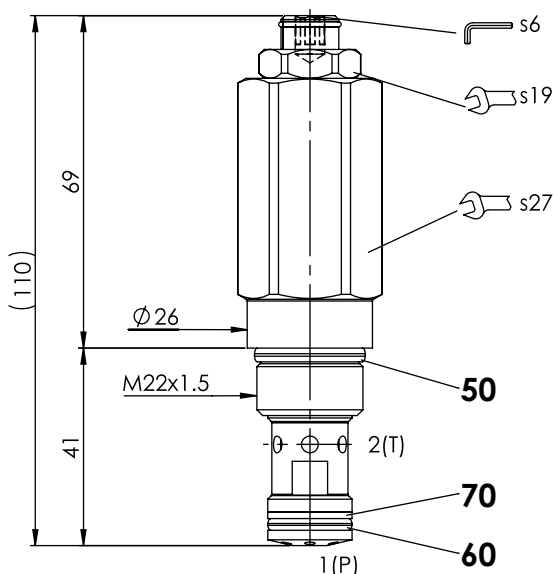
BESPM22-420 ...

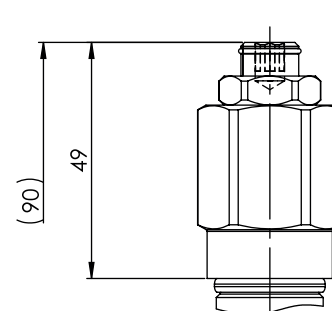

BESPM22-63



HYDRAULIC CONNECTION

Cavity drawing according to ISO 7789-22-02-0-98

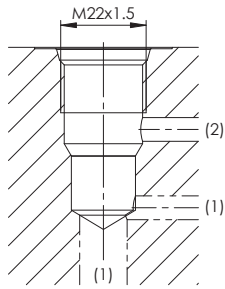
Note!

For detailed cavity drawing and cavity tools see data sheet 2.13-1003

ACCESSORIES

Flange body / sandwich plate NG4-Mini	Data sheet 2.1-620
Flange body / sandwich plate NG6	Data sheet 2.1-640
Flange body / sandwich plate NG10	Data sheet 2.1-660
Threaded body	Data sheet 2.9-200
Technical explanations	Data sheet 1.0-100
Hydraulic fluids	Data sheet 1.0-50
Filtration	Data sheet 1.0-50

PARTS LIST

Position	Article	Description
		Seal kit consisting of
50	O-ring	ID 18,77 x 1,78
60	O-ring	ID 14,00 x 1,78
70	Back. ring	PTFE rd 14,6 x 17,5 x 1,4

SURFACE TREATMENT

- ◆ The cartridge body is zinc-nickel coated

SEALING MATERIAL

NBR or FKM (Viton) as standard, choice in the type code

INSTALLATION NOTES

Mounting type	Screw-in cartridge M22 x 1,5
Mounting position	Any
Tightening torque	$M_D = 60 \text{ Nm}$ Screw-in cartridge

STANDARDS

Cartridge cavity	ISO 7789
Contamination efficiency	ISO 4406